

400Gbps QSFP DD Passive High Speed Cable Specification

1 Description :

QSFP-DD (Double Density) has eight-channel electrical interfaces, with data transmission rates up to 28Gbps NRZ or 56Gbps PAM4, and total data rates up to 200Gbps or 400Gbps. QSFP-DD connectors and cable assemblies comply with IEEE 802.3bj, InfiniBand EDR and SAS 3.0 specifications, so they are suitable for various next-generation technologies and applications

2 Product Features

- Comply with SFF-8636&QSFP-DD MSA
- Complies with Ethernet IEEE802.3bj/IEEE 802.3cd
- Support serial ID function through EEPROM
- Support hot swap, low crosstalk, low power consumption
- Support the maximum distance of 3 meters
- Operating temperature range: 0°C to 70°C
- RoHS compliant
- Eight-lane electrical interface transmits up to 28Gbps NRZ or 56Gbps PAM4

3 Applications :

- 200g/400g Ethernet
- Switches, routers, servers, hubs, data center cabling

4 Outline drawing:

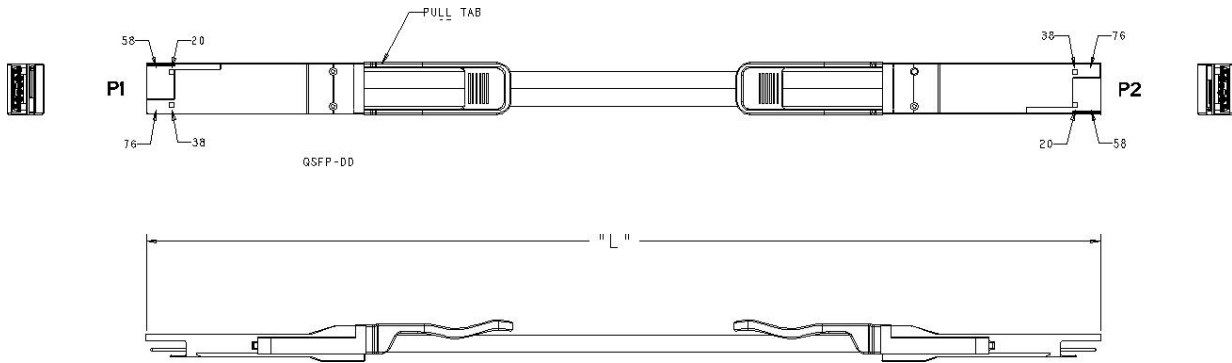

5 Wiring Diagram:

P1			P2	
GND	1		20	GND
TX2-	2	↔	21	RX2-
TX2+	3	↔	22	RX2+
GND	4		23	GND
TX4-	5	↔	24	RX4-
TX4+	6	↔	25	RX4+
GND	7		26	GND
ModseIL	8		27	ModPrsL
ReseIL	9		28	InIL
VccRx	10		29	VccTx
SCL	11		30	VccI
SDA	12		31	InitMode
GND	13		32	GND
RX3+	14	↔	33	TX3+
RX3-	15	↔	34	TX3-
GND	16		35	GND
RX1+	17	↔	36	TX1+
RX1-	18	↔	37	TX1-
GND	19		38	GND
GND	20		1	GND
RX2-	21	↔	2	TX2-
RX2+	22	↔	3	TX2+
GND	23		4	GND
RX4-	24	↔	5	TX4-
RX4+	25	↔	6	TX4+
GND	26		7	GND
ModPrsL	27		8	ModseIL
InIL	28		9	ReseIL
VccTx	29		10	VccRx
VccI	30		11	SCL
InitMode	31		12	SDA
GND	32		13	GND
TX3+	33	↔	14	RX3+
TX3-	34	↔	15	RX3-
GND	35		16	GND
TX1+	36	↔	17	RX1+
TX1-	37	↔	18	RX1-
GND	38		19	GND

P1			P2	
GND	39		58	GND
TX6-	40	↔	59	RX6-
TX6+	41	↔	60	RX6+
GND	42		61	GND
TX8-	43	↔	62	RX8-
TX8+	44	↔	63	RX8+
GND	45		64	GND
Reserved	46		65	NC
VS1	47		66	Reserved
VccRx1	48		67	VccTx1
VS2	49		68	Vcc2
VS3	50		69	Reserved
GND	51		70	GND
RX7+	52	↔	71	TX7+
RX7-	53	↔	72	TX7-
GND	54		73	GND
RX5+	55	↔	74	TX5+
RX5-	56	↔	75	TX5-
GND	57		76	GND
GND	58		39	GND
RX6-	59	↔	40	TX6-
RX6+	60	↔	41	TX6+
GND	61		42	GND
RX8-	62	↔	43	TX8-
RX8+	63	↔	44	TX8+
GND	64		45	GND
NC	65		46	Reserved
Reserved	66		47	VS1
VccTx1	67		48	VccRx1
Vcc2	68		49	VS2
Reserved	69		50	VS3
GND	70		51	GND
TX7+	71	↔	52	RX7+
TX7-	72	↔	53	RX7-
GND	73		54	GND
TX5+	74	↔	55	RX5+
TX5-	75	↔	56	RX5-
GND	76		57	GND

6 Electrical Performance:

6.1 (Signal Integrity)

(ITEM)		(REQUIREMENT)	(TEST CONDITION)					
(Differential Impedance)	Cable Impedance	105+5/-10Ω	Rise time of 25ps (20% - 80%).					
	Paddle Card Impedance	100±10Ω						
	Cable Termination Impedance	100±15Ω						
[Differential (Input/Output)Return loss S_{DD11}/S_{DD22}]		$\text{Return_loss}(f) \geq \left\{ \begin{array}{ll} 16.5-2\sqrt{f} & 0.05 \leq f < 4.1 \\ 10.66-14\log_{10}(f/5.5) & 4.1 \leq f \leq 19 \end{array} \right\}$ Where f is the frequency in GHz	10MHz ≤ f ≤ 19GHz					
[Differential to common-mode (Input/Output)Return loss S_{CD11}/S_{CD22}]		$\text{Return_loss}(f) \geq \left\{ \begin{array}{ll} 22-(20/25.78)f & 0.01 \leq f < 12.89 \\ 15-(6/25.78)f & 12.89 \leq f \leq 19 \end{array} \right\}$ Where f is the frequency in GHz Return_loss(f) is the Differential to common-mode return loss at frequency f	10MHz ≤ f ≤ 19GHz					
[Common-mode to Common-mode (Input/Output)Return loss S_{CC11}/S_{CC22}]		$\text{Return_loss}(f) \geq 2\text{dB} \quad 0.2 \leq f \leq 19$ Where f is the frequency in GHz Return_loss(f) is the common-mode to common-mode return loss at frequency f	10MHz ≤ f ≤ 19GHz					
[Differential Insertion Loss (S_{DD21} Max.)]		(Differential InsertionLoss Max. For TPa to TPb Excluding Test fixture)					10MHz ≤ f ≤ 19GHz	
F / AWG		1.25GHz	2.5GHz	5.0GHz	7.0GHz	10Ghz		12.89Ghz
30(1m) Max.		4.5dB	5.4dB	6.3dB	7.5dB	8.5dB		10.5dB
30/28(3m)Max.		7.5dB	9.5dB	12.2dB	14.8dB	18.0dB		21.5dB
26(3m) Max.		5.7dB	7.2dB	9.9 dB	11.9dB	14.1dB	16.5dB	

	26/25(5m)Max.	7.8dB	10.0dB	13.5dB	16.0dB	19.0dB	22.0dB	
	x.							
Differential to common-mode Conversion Loss-Differential Insertion Loss($S_{CD21}-S_{DD21}$)	$\text{Conversion_loss}(f) - \text{IL}(f) \geq \begin{cases} 10 & 0.01 \leq f < 12.89 \\ 27-(29/22)f & 12.89 \leq f < 19 \end{cases}$ <p>Where f is the frequency in GHz $\text{Conversion_loss}(f)$ is the cable assembly differential to common-mode conversion loss $\text{IL}(f)$ is the cable assembly insertion loss</p>							10MHz \leq f \leq 19GHz
[MDNEXT(multiple disturber near-end crosstalk)]	$\geq 26\text{dB @ } 12.89\text{GHz}$							10MHz \leq f \leq 19GHz

6.2 (Other Electrical Performance)

(ITEM)	(REQUIREMENT)	(TEST CONDITON)
[Low Level Contact Resistance]	70milliohms Max. From initial.	EIA-364-23:Apply a maximum voltage of 20mV And a current of 100 mA.
Insulation Resistance	10Mohm(Min.)	EIA364-21:AC 300V 1minute
[Dielectric Withstanding Voltage]	NO disruptive discharge.	EIA-364-20:Apply a voltage of 300 VDC for 1minute between adjacent terminals And between adjacent terminals and ground.

7 Environment Performance

(ITEM)	(REQUIREMENT)	(TEST CONDITON)
[Operating Temp. Range]	-20°C to +75°C	Cable operating temperature range.
[Storage Temp. Range (in packed condition)]	-40°C to +80°C	Cable storage temperature range in packed condition.
[Thermal Cycling Non-Powered]	No evidence of physical damage	EIA-364-32D, Method A, -25 to 90C, 100 cycles, 15 min. dwells
Salt Spraying]	48 hours salt spraying after shell corrosive area less than 5%.	EIA-364-26
Mixed Flowing Gas	Pass electrical tests per 3.1 after stressing. (For connector only)	EIA-364-35 Class II, 14 days.
Temp. Life	No evidence of physical damage	EIA-364-17C w/ RH, Damp heat 90°C at 85% RH for 500 hours then return to ambient
Cable Cold Bend	4H, No evidence of physical damage	Condition: -20°C±2°C, mandrel diameter is 6 times the cable diameter.

8 Mechanical and Physical Characteristics

(ITEM)	(REQUIREMENT)	(TEST CONDITON)
Vibration	Pass electrical tests per 3.1 after stressing.	Clamp & vibrate per EIA-364-28E, TC-VII, test condition letter – D, 15 minutes in X, Y & Z axis.
Cable Flex	No evidence of physical damage	Flex cable 180° for 20 cycles ($\pm 90^\circ$ from nominal position) at 12 cycles per minute with a 1.0kg load applied to the cable jacket. Flex in the boot area 90° in each direction from vertical. Per EIA-364-41C
Cable Plug Retention in Cage	90N Min. No evidence of physical damage	Force to be applied axially with no damage to cage. Per SFF 8661 Rev 2.1 Pull on cable jacket approximately 1 ft behind cable plug. No functional damage to cable plug below 90N. Per SFF-8432 Rev 5.0
Cable Retention in Plug	90N Min. No evidence of physical damage	Cable plug is fixtured with the bulk cable hanging vertically. A 90N axial load is applied (gradually) to the cable jacket and held for 1 minute. Per EIA-364-38B
Mechanical Shock	Pass electrical tests Per 3.1 after stressing.	Clamp and shock per EIA-364-27B, TC-G, 3 times in 6 directions, 100g, 6ms.
Cable Plug Insertion	40N Max.(QSFP56) 90N Max.(QSFP DD)	Per SFF8661 Rev 2.1 Per QSFP-DD Hardware Rev 5.0
Cable plug Extraction	30N Max. (QSFP56) 50N Max.(QSFP DD)	Place axial load on de-latch to de-latch plug.Per SFF8661 Rev 2.1 Measure without the aid of any cage kick-out springs. Place axial load on de-latch to de-latch plug. Per SFF-8432 Rev 5.0
Durability	50 cycles, No evidence of physical damage	EIA-364-09, perform plug & unplug cycles: Plug and receptacle mate rate: 250times/hour. 50times for QSFP28/SFP28 module (CONNECTOR TO PCB)