

## **XFDXX1T40DC**

### **10Gb/s 40km DWDM XFP Optical Transceiver**

#### **PRODUCT FEATURES**

- Hot-pluggable XFP footprint
- Supports 9.95Gb/s to 11.3Gb/s bit rates
- Supports Lineside and XFI loopback
- RoHS-6 Compliant (lead-free)
- Power dissipation <3.5W
- Case temperature range: -10°C to 70°C
- Maximum link length of 40km
- Cooled DWDM EML
- PIN-TIA Receiver
- Full Duplex LC connector
- No Reference Clock required
- Built-in digital diagnostic functions
- Standard bail release mechanism

#### **APPLICATIONS**

- DWDM 10GBASE-ER/EW 10G Ethernet
- DWDM 40KM 10G Fiber Channel
- DWDM SONET OC-192&SDH STM-64

## PRODUCT DESCRIPTION

XFDXX1T40DC Small Form Factor 10Gb/s (XFP) transceivers are compliant with the current XFP Multi-Source Agreement (MSA) Specification. They comply with 10-Gigabit Ethernet 10GBASE-ER/EW per IEEE 802.3ae. Digital diagnostics functions are available via a 2-wire serial interface, as specified in the XFP MSA. The transceiver is RoHS compliant and leads free per Directive 2002/95/EC<sup>3</sup>

### I. Absolute Maximum Ratings

| Parameter                  | Symbol            | Min  | Typ | Max | Unit | Ref. |
|----------------------------|-------------------|------|-----|-----|------|------|
| Maximum Supply Voltage 1   | Vcc3              | -0.5 |     | 4.0 | V    |      |
| Maximum Supply Voltage 2   | Vcc5              | -0.5 |     | 6.0 | V    |      |
| Storage Temperature        | T <sub>s</sub>    | -40  |     | 85  | °C   |      |
| Case Operating Temperature | T <sub>case</sub> | -10  |     | 70  | °C   |      |

### II. Electrical Characteristics (T<sub>OP</sub> = -10 to 70, V<sub>CC3</sub> = 3.13 to 3.45 Volts)

| Parameter                      | Symbol                 | Min                   | Typ              | Max                 | Unit | Ref. |
|--------------------------------|------------------------|-----------------------|------------------|---------------------|------|------|
| Main Supply Voltage            | Vcc5                   | 4.75                  |                  | 5.25                | V    |      |
| Supply Voltage #2              | Vcc3                   | 3.13                  |                  | 3.45                | V    |      |
| Supply Current – Vcc5 supply   | Icc5                   |                       |                  | 320                 | mA   |      |
| Supply Current – Vcc3 supply   | Icc3                   |                       |                  | 400                 | mA   |      |
| Module total power             | P                      |                       |                  | 3.5                 | W    | 1    |
| <b>Transmitter</b>             |                        |                       |                  |                     |      |      |
| Input differential impedance   | R <sub>in</sub>        |                       | 100              |                     | Ω    | 2    |
| Differential data input swing  | V <sub>in,pp</sub>     | 120                   |                  | 820                 | mV   |      |
| Transmit Disable Voltage       | V <sub>D</sub>         | 2.0                   |                  | V <sub>CC</sub>     | V    | 3    |
| Transmit Enable Voltage        | V <sub>EN</sub>        | GND                   |                  | GND+ 0.8            | V    |      |
| Transmit Disable Assert Time   |                        |                       |                  | 10                  | us   |      |
| <b>Receiver</b>                |                        |                       |                  |                     |      |      |
| Differential data output swing | V <sub>out,pp</sub>    | 340                   | 650              | 850                 | mV   | 4    |
| Data output rise time          | t <sub>r</sub>         |                       |                  | 38                  | ps   | 5    |
| Data output fall time          | t <sub>f</sub>         |                       |                  | 38                  | ps   | 5    |
| LOS Fault                      | V <sub>LOS fault</sub> | V <sub>CC</sub> – 0.5 |                  | V <sub>CCHOST</sub> | V    | 6    |
| LOS Normal                     | V <sub>LOS norm</sub>  | GND                   |                  | GND+0.5             | V    | 6    |
| Power Supply Rejection         | PSR                    |                       | See Note 6 below |                     |      | 7    |

#### Notes:

1. Maximum total power value is specified across the full temperature and voltage range.
2. After internal AC coupling.
3. Or open circuit.
4. Into 100 ohms differential termination.
5. These are unfiltered 20-80% values

6. Loss Of Signal is open collector to be pulled up with a 4.7k – 10kohm resistor to 3.15 – 3.6V. Logic 0 indicates normal operation; logic 1 indicates no signal detected.
7. Per Section 2.7.1. in the XFP MSA Specification1

### III. Optical Characteristics (TOP = -10 to 70, VCC3 = 3.13 to 3.45 Volts)

| Parameter                               | Symb<br>ol         | Min                 | Typ            | Max                 | Unit      | Ref |
|---|--------------------|---------------------|----------------|---------------------|-----------|-----|
| <b>Transmitter</b>                      |                    |                     |                |                     |           |     |
| Average Optical Power                   | P <sub>f</sub>     | 0                   |                | 4                   | dBm       |     |
| Center Wavelength (BOL)                 | λ <sub>c</sub>     | λ <sub>c</sub> -25  | λ <sub>c</sub> | λ <sub>c</sub> +25  | pm        |     |
| Center Wavelength (EOL)                 | λ <sub>c</sub>     | λ <sub>c</sub> -100 | λ <sub>c</sub> | λ <sub>c</sub> +100 | pm        |     |
| Tx Jitter Generation(peak-to-peak)      | T <sub>xj1</sub>   |                     |                | 0.3                 | UI        |     |
| Tx Jitter Generation(RMS)               | T <sub>xj2</sub>   |                     |                | 0.1                 | UI        |     |
| Sidemode Suppression ratio              | SSR <sub>min</sub> | 30                  |                |                     | dB        |     |
| Optical Extinction Ratio                | ER                 | 8.2                 |                |                     | dB        |     |
| Transmitter and Dispersion Penalty      | TDP                |                     |                | 2                   | dB        |     |
| Average Launch power of OFF transmitter | P <sub>OFF</sub>   |                     |                | -30                 | dBm       |     |
| Relative Intensity Noise                | RIN                |                     |                | -130                | dB/H<br>z |     |
| <b>Receiver</b>                         |                    |                     |                |                     |           |     |
| Receiver Sensitivity                    | R <sub>SENS</sub>  |                     |                | -24(10.3125Gb/s)    | dBm       | 1   |
|   |                    |                     |                | -22<br>(11.1Gb/s)   | dBm       | 1   |
| Input Saturation Power (Overload)       | P <sub>sat</sub>   | -6                  |                |                     | dBm       |     |
| Wavelength Range                        | λ <sub>c</sub>     | 1260                |                | 1600                | nm        |     |
| Receiver Reflectance                    | R <sub>rx</sub>    |                     |                | -27                 | dB        |     |
| LOS De-Assert                           | LOS <sub>D</sub>   |                     |                | -27                 | dBm       |     |
| LOS Assert                              | LOS <sub>A</sub>   | -37                 |                |                     | dBm       |     |
| LOS Hysteresis                          |                    | 0.5                 |                |                     | dB        |     |

Notes:

1. Measured with worst ER; BER < 10<sup>-12</sup>, 2<sup>31</sup> – 1 PRBS.

## IV. Pin Descriptions

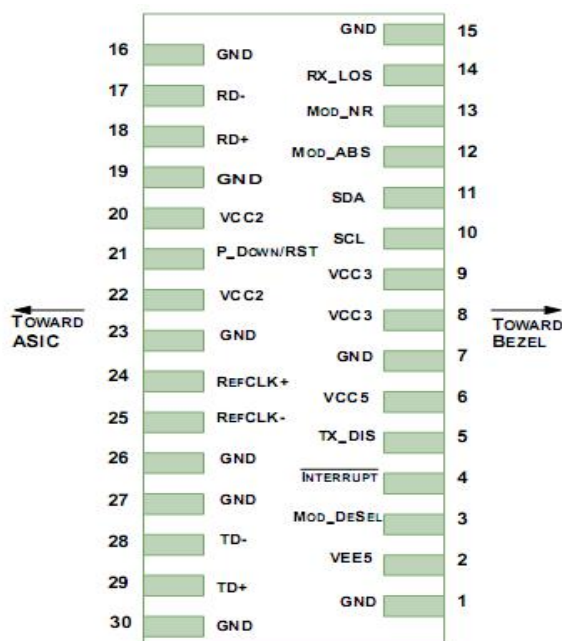

Diagram of Host Board Connector Block Pin Numbers and Name

| Pin | Logic     | Symbol    | Name/Description   | Ref |
|-----|-----------|-----------|--|-----|
| 1   |           | GND       | Module Ground  | 1   |
| 2   |           | VEE5      | Optional -5.2 Power Supply – <b>Not required</b>   |     |
| 3   | LVTTL-I   | Mod-Desel | Module De-select; When held low allows the module to respond to 2-wire serial interface commands                 |     |
| 4   | LVTTL-O   | Interrupt | Interrupt (bar); Indicates presence of an important condition which can be read over the serial 2-wire interface | 2   |
| 5   | LVTTL-I   | TX_DIS    | Transmitter Disable; Transmitter laser source turned off   |     |
| 6   |           | VCC5      | +5 Power Supply  |     |
| 7   |           | GND       | Module Ground  | 1   |
| 8   |           | VCC3      | +3.3V Power Supply   |     |
| 9   |           | VCC3      | +3.3V Power Supply   |     |
| 10  | LVTTL-I   | SCL       | Serial 2-wire interface clock  | 2   |
| 11  | LVTTL-I/O | SDA       | Serial 2-wire interface data line  | 2   |
| 12  | LVTTL-O   | Mod_Abs   | Module Absent; Indicates module is not present. Grounded in the module.  | 2   |
| 13  | LVTTL-O   | Mod_NR    | Module Not Ready; Fiberate defines it as a logical OR between RX_LOS and Loss of Lock in TX/RX.                  | 2   |
| 14  | LVTTL-O   | RX_LOS    | Receiver Loss of Signal indicator  | 2   |
| 15  |           | GND       | Module Ground  | 1   |
| 16  |           | GND       | Module Ground  | 1   |
| 17  | CML-O     | RD-       | Receiver inverted data output  |     |
| 18  | CML-O     | RD+       | Receiver non-inverted data output  |     |
| 19  |           | GND       | Module Ground  | 1   |
| 20  |           | VCC2      | +1.8V Power Supply – <b>Not required</b>   |     |

|    |          |                |  |   |
|----|----------|----------------|--|---|
| 21 | LVTTTL-I | P_Down/RS<br>T | Power Down; When high, places the module in the low power stand-by mode and on the falling edge of P_Down initiates a module reset   |   |
|    |          |                | Reset; The falling edge initiates a complete reset of the module including the 2-wire serial interface, equivalent to a power cycle. |   |
| 22 |          | VCC2           | +1.8V Power Supply – <b>Not required</b>   |   |
| 23 |          | GND            | Module Ground  | 1 |
| 24 | PECL-I   | RefCLK+        | Reference Clock non-inverted input, AC coupled on the host board – <b>Not required</b>   | 3 |
| 25 | PECL-I   | RefCLK-        | Reference Clock inverted input, AC coupled on the host board – <b>Not required</b>   | 3 |
| 26 |          | GND            | Module Ground  | 1 |
| 27 |          | GND            | Module Ground  | 1 |
| 28 | CML-I    | TD-            | Transmitter inverted data input  |   |
| 29 | CML-I    | TD+            | Transmitter non-inverted data input  |   |
| 30 |          | GND            | Module Ground  | 1 |

**Notes:**

1. Module circuit ground is isolated from module chassis ground within the module.
2. 2 Open collector; should be pulled up with 4.7k – 10kohms on host board to a voltage between 3.15V and 3.6V.
3. A Reference Clock input is not required by the XFDXX1T40DC. If present, it will be ignored.

## V. General Specifications

| Parameter                  | Symbol           | Min  | Typ | Max               | Units | Ref. |
|----------------------------|------------------|------|-----|-------------------|-------|------|
| Bit Rate                   | BR               | 9.95 |     | 11.3              | Gb/s  | 1    |
| Bit Error Ratio            | BER              |      |     | 10 <sup>-12</sup> |       | 2    |
| Max. Supported Link Length | L <sub>MAX</sub> |      | 40  |                   | km    | 1    |

**Notes:**

1. 10GBASE-ER/EW
2. Tested with 2<sup>31</sup> – 1 PRBS

## VI. Digital Diagnostic Functions

As defined by the XFP MSA1, Fiberate XFP transceivers provide digital diagnostic functions via a 2-wire serial interface, which allows real-time access to the following operating parameters:

- Transceiver temperature
- Laser bias current
- Transmitted optical power
- Received optical power
- Transceiver supply voltage

It also provides a sophisticated system of alarm and warning flags, which may be used to alert end-users when particular operating parameters are outside of a factory-set normal range.

The operating and diagnostics information is monitored and reported by a Digital Diagnostics Transceiver Controller (DDTC) inside the transceiver, which is accessed through the 2-wire serial interface. When the serial protocol is activated, the serial clock signal (SCL pin) is generated by the host. The positive edge clocks data into the XFP transceiver into those segments of its memory map that are not write-protected. The negative edge clocks data from the XFP transceiver. The serial data signal (SDA pin) is bi-directional for serial data transfer. The host uses SDA in conjunction with SCL to mark the start and end of serial protocol activation. The memories are organized as a series of 8-bit data words that can be addressed individually or sequentially. The 2-wire serial interface provides sequential or random access to the 8 bit parameters, addressed from 000h to the maximum address of the memory.

For more detailed information including memory map definitions, please see the XFP MSA Specification.

## VII. XFDXX1T40DC center wavelength

### C-band $\lambda_c$ Wavelength Guide Pin Descriptions

| Channel    | Wavelength (nm) | Frequency (THZ) | Channel    | Wavelength (nm) | Frequency (THZ) |
|------------|-----------------|-----------------|------------|-----------------|-----------------|
| <b>C13</b> | 1567.13         | 191.30          | <b>C37</b> | 1547.72         | 193.70          |
| <b>C14</b> | 1566.31         | 191.40          | <b>C38</b> | 1546.92         | 193.80          |
| <b>C15</b> | 1565.50         | 191.50          | <b>C39</b> | 1546.12         | 193.90          |
| <b>C16</b> | 1564.68         | 191.60          | <b>C40</b> | 1545.32         | 194.00          |
| <b>C17</b> | 1563.86         | 191.70          | <b>C41</b> | 1544.53         | 194.10          |
| <b>C18</b> | 1563.05         | 191.80          | <b>C42</b> | 1543.73         | 194.20          |
| <b>C19</b> | 1562.23         | 191.90          | <b>C43</b> | 1542.94         | 194.30          |
| <b>C20</b> | 1561.42         | 192.00          | <b>C44</b> | 1542.14         | 194.40          |
| <b>C21</b> | 1560.61         | 192.10          | <b>C45</b> | 1541.35         | 194.50          |
| <b>C22</b> | 1559.79         | 192.20          | <b>C46</b> | 1540.56         | 194.60          |
| <b>C23</b> | 1558.98         | 192.30          | <b>C47</b> | 1539.77         | 194.70          |
| <b>C24</b> | 1558.17         | 192.40          | <b>C48</b> | 1538.98         | 194.80          |

|                |  |        |            |         |        |
|----------------|--|--------|------------|---------|--------|
| <b>C25</b>     | 1557.36  | 192.50 | <b>C49</b> | 1538.19 | 194.90 |
| <b>C26</b>     | 1556.55  | 192.60 | <b>C50</b> | 1537.40 | 195.00 |
| <b>C27</b>     | 1555.75  | 192.70 | <b>C51</b> | 1536.61 | 195.10 |
| <b>C28</b>     | 1554.94  | 192.80 | <b>C52</b> | 1535.82 | 195.20 |
| <b>C29</b>     | 1554.13  | 192.90 | <b>C53</b> | 1535.04 | 195.30 |
| <b>C30</b>     | 1553.33  | 193.00 | <b>C54</b> | 1534.25 | 195.40 |
| <b>C31</b>     | 1552.52  | 193.10 | <b>C55</b> | 1533.47 | 195.50 |
| <b>C32</b>     | 1551.72  | 193.20 | <b>C56</b> | 1532.68 | 195.60 |
| <b>C33</b>     | 1550.92  | 193.30 | <b>C57</b> | 1531.90 | 195.70 |
| <b>C34</b>     | 1550.12  | 193.40 | <b>C58</b> | 1531.12 | 195.80 |
| <b>C35</b>     | 1549.32  | 193.50 | <b>C59</b> | 1530.33 | 195.90 |
| <b>C36</b>     | 1548.51  | 193.60 | <b>C60</b> | 1529.55 | 196.00 |
| <b>Non-ITU</b> | <b>Peak wavelength between<br/>1528.77nm-1567.13</b> |        | <b>C61</b> | 1528.77 | 196.10 |

## VIII. Mechanical Specifications

Fiberate's XFP transceivers are compliant with the dimensions defined by the XFP Multi-Sourcing Agreement (MSA).

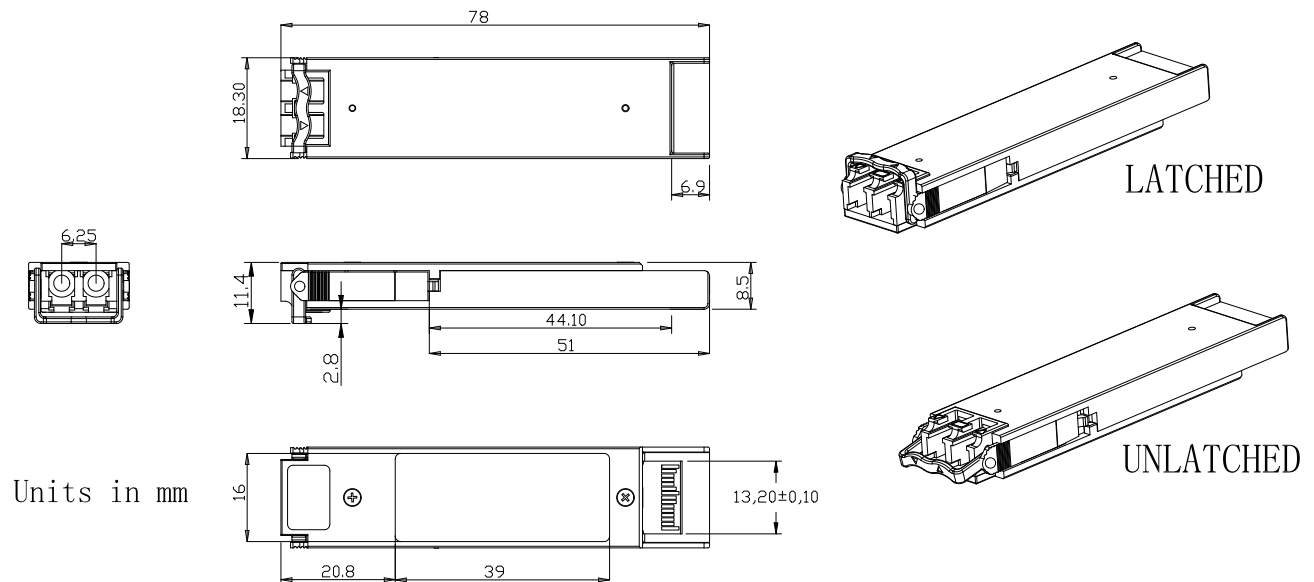

XFP Transceiver (dimensions are in mm)

### IX. PCB Layout and Bezel Recommendations

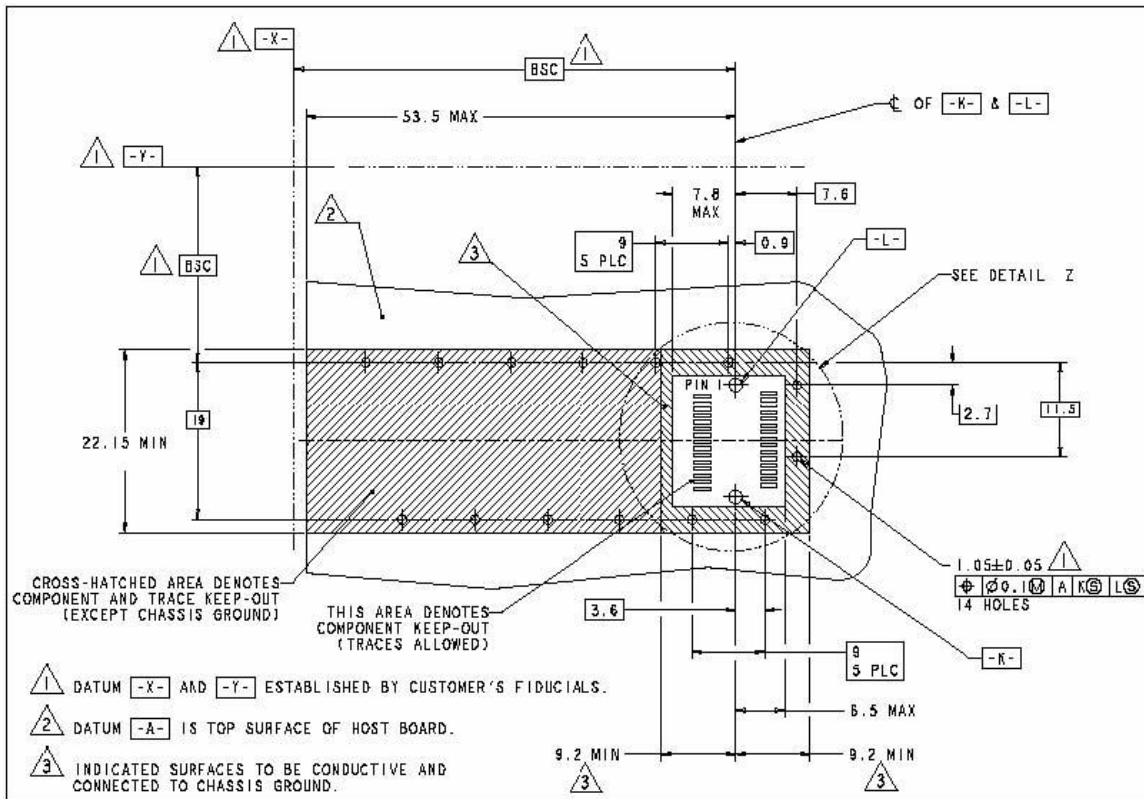

**XFP Host Board Mechanical Layout (dimensions are in mm)**

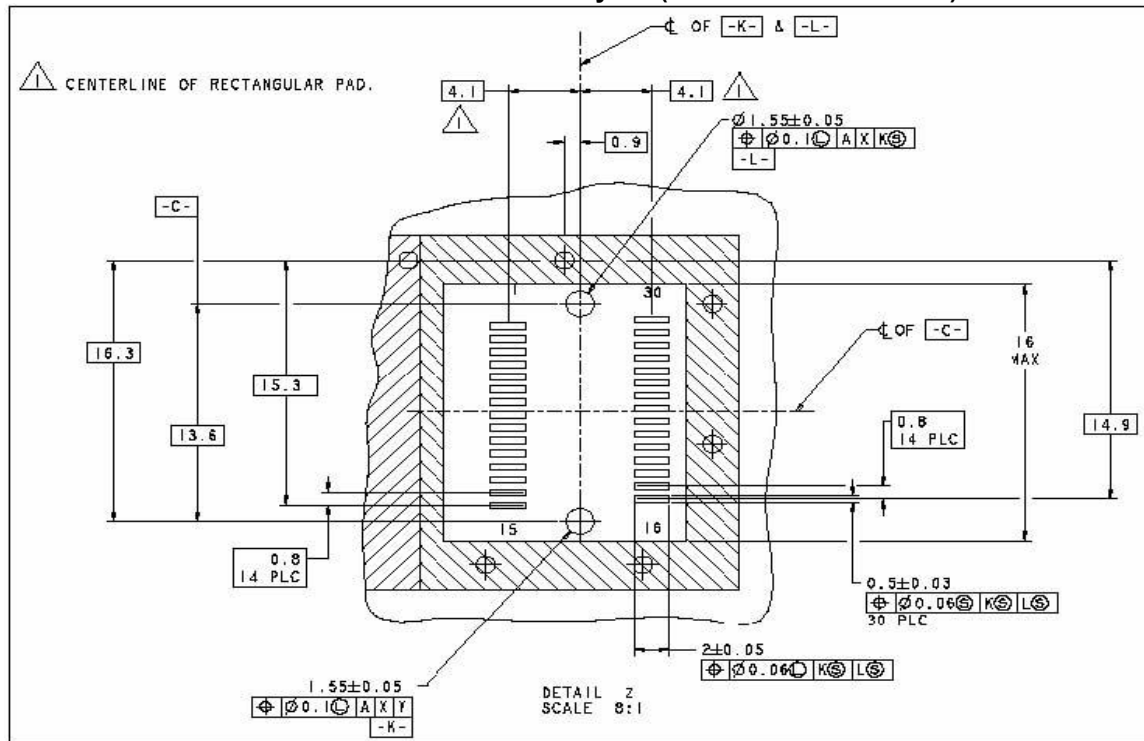

**XFP Detail Host Board Mechanical Layout (dimensions are in mm)**



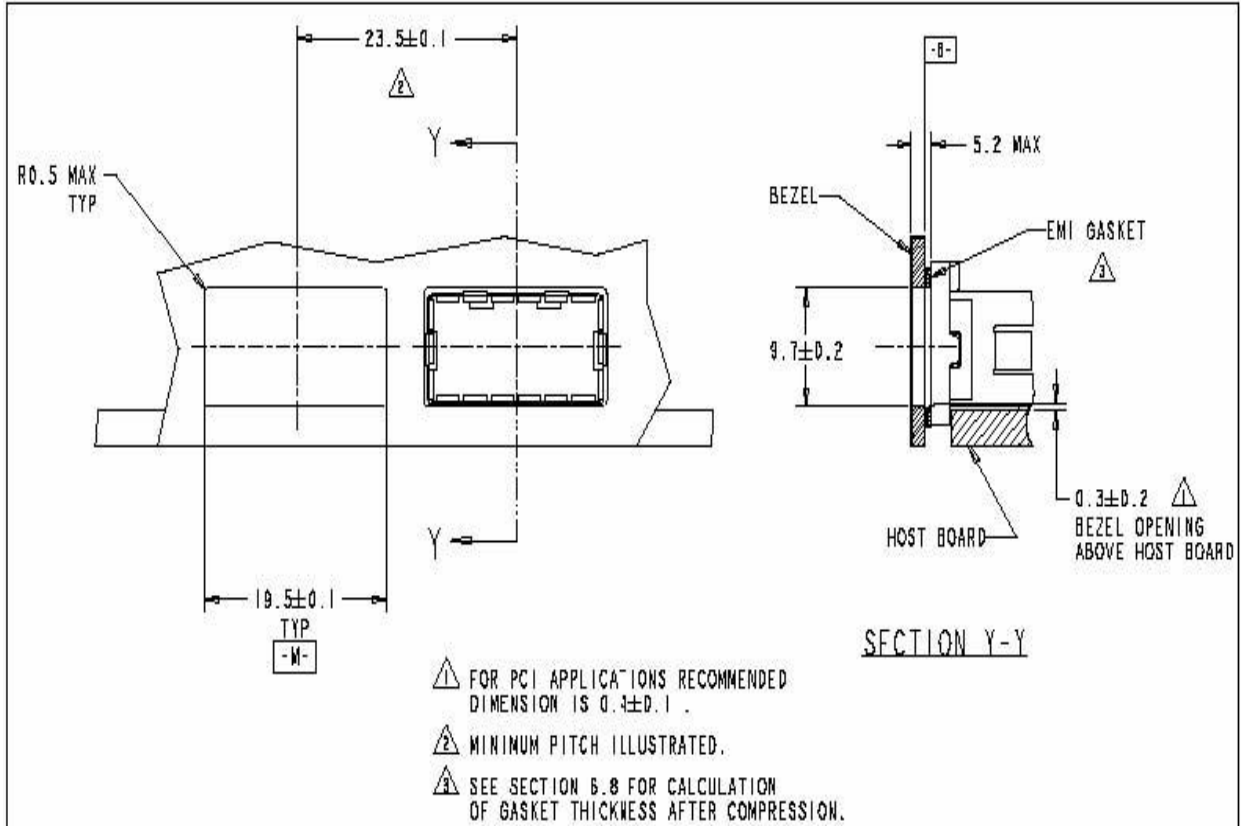

## X. Regulatory Compliance

| Feature                            | Reference   | Performance               |
|------------------------------------|---|---------------------------|
| Electrostatic discharge (ESD)      | IEC/EN 61000-4-2                                    | Compatible with standards |
| Electromagnetic Interference (EMI) | FCC Part 15 Class B EN 55022<br>Class B (CISPR 22A) | Compatible with standards |
| Laser Eye Safety                   | FDA 21CFR 1040.10, 1040.11<br>IEC/EN 60825-1, 2     | Class 1 laser product     |
| Component Recognition              | IEC/EN 60950 , UL                                   | Compatible with standards |
| ROHS                               | 2002/95/EC  | Compatible with standards |
| EMC                                | EN61000-3   | Compatible with standards |